

NWCT SERIES USERS MANUAL

TRUE RMS CURRENT TRANSFORMER



TABLE OF CONTENTS

1. Ordering Codes.....2

2. Description2

 2.1 Features.....2

3. Installation / Safety Information.....3

 3.1 Limited Warranty.....3

 3.2 Mounting Instructions.....3

 3.3 Electrical Connections4

4. Operation4

 4.1 Power Supply.....4

 4.2 24V Power Fusing.....4

 4.3 Zero and Span Adjustment4

 4.4 Zero and Span Factory Calibration / Range.....5

 4.5 Power/Overload LED5

5. Electrical Specifications5

6. Mechanical Dimensions5

7. Contact Information.....6

8. WIRING DIAGRAM.....6

1. Ordering Codes

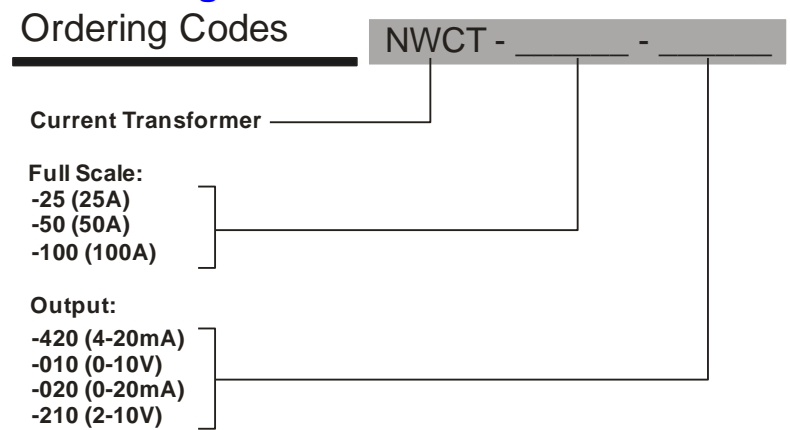

2. Description

The NWCT is a current transformer/transducer that provides a 0-10V or 4-20mA output that is proportional to the current signal present on the conductor passed through the on-board sense transformer. The major advantage to the NWCT is that it can accurately sense nonlinear and distorted sinusoidal signals such as phase controlled loads and provide a True RMS conversion of the signal. Less sophisticated current transformer units suffer from severely inaccurate conversion of these types of signals. This is because they tend to respond only to the instantaneous peaks of the signal which have nothing to do with the actual current present in the load circuit. The NWCT is a major improvement over these designs, offering greater accuracy, stability and flexibility.

2.1 Features

- True RMS Current monitoring of sinusoidal and distorted signals
- 4-20mA or 0-10V output
- Adjustable Zero and span
- Power/Overload Indicator LED
- Din Rail Mount

- Low Cost

3. Installation / Safety Information

Responsibility for determining suitability for use in any application / equipment lies solely on the purchaser, OEM and end user. Suitability for use in your application is determined by applicable standards such as UL, cUL and CE and the completed system involving this component should be tested to those standards.



WARNING: FIRE HAZARD!! Even quality electronic components **CAN FAIL KEEPING FULL POWER ON!** Provide a **SEPARATE (redundant) OVER TEMPERATURE SHUTDOWN DEVICE** to switch the power off if safe temperatures are exceeded.

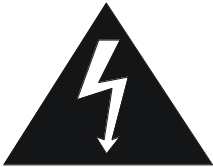

WARNING: HIGH VOLTAGE!! This unit is installed in an electrical system with high voltage in it. This control must be installed in a **GROUND**ED enclosure by a qualified electrician in accordance with applicable local and national codes including NEC and other applicable codes. Provide a safety interlock on the door to remove power before gaining access to the device.

3.1 Limited Warranty

NuWave Technologies, Inc. warrant this product to be free from defect in workmanship and materials for a period of two (2) years from the date of purchase.

1. Should unit malfunction, return it to the factory. If defective it will be repaired or replaced at no charge.
2. There are no user serviceable parts on this unit. This warranty is void if the unit shows evidence of being tampered with or subjected to excessive heat, moisture, corrosion or other misuse / misapplication.
3. Components which wear or damage with misuse are excluded, e.g. relays.
4. NuWave Technologies, Inc. shall not be responsible for any damage or losses however caused, which may be experienced as a result of the installation or use of this product. NuWave Technologies, Inc. liability for any breach of this agreement shall not exceed the purchase price paid E. & O.E.

3.2 Mounting Instructions

The NWCT fits most dinrail tracks: DIN EN 50022, 50035, and 50045. To mount, simply interlock the non-tabbed end and then push the tabbed end onto the dinrail. To remove, pry tab using a small screwdriver.

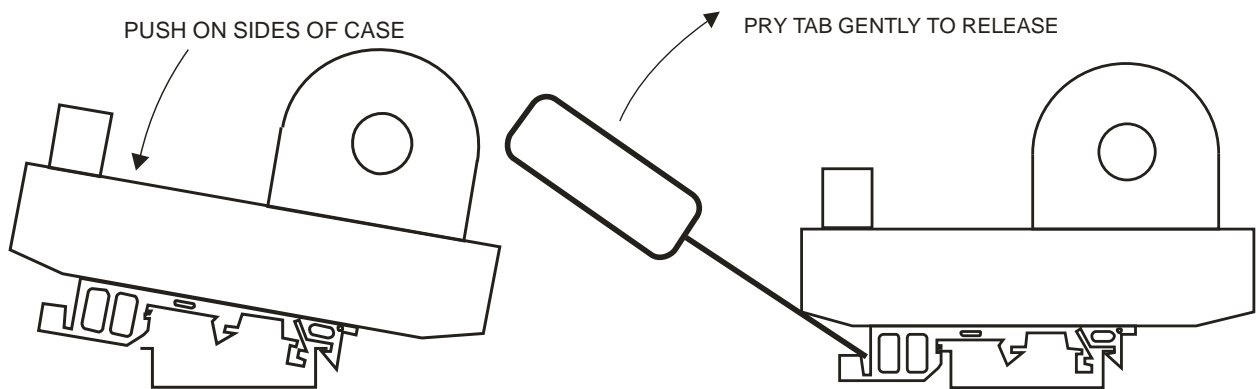

3.3 Electrical Connections

See the WIRING DIAGRAMS at the end of this document. Make sure the unit ordered is the correct unit for the application before wiring.

4. Operation

4.1 Power Supply

The NWCT power requirement is 24V AC/DC +/-15% 47-400Hz.

4.2 24V Power Fusing

Fusing may be accomplished by fusing each unit separately or fusing groups of the units with either primary or secondary fusing. The current draw of each NWCT is 40mA max.

4.3 Zero and Span Adjustment

The output of the NWCT has adjustable zero and span pots (potentiometers). These allow the adjustment of the 0-10V or 4-20mA output to provide flexibility in a large variety of applications. The graph below shows the input/output response of the NWCT-100-420 (100A FS, 4-20mA output) and the action of the zero and span adjustments. In the example equation $\text{Output} = mx+b$, Zero is offset or intercept (b) and Span is slope (m).

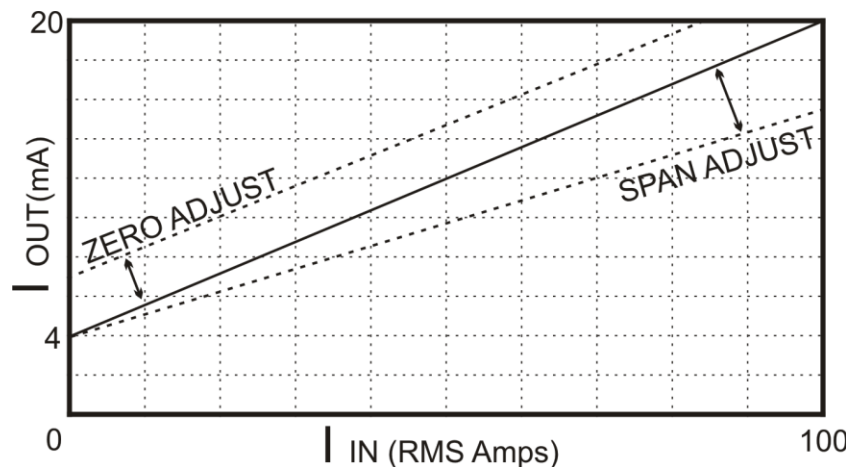

Graph of Input / Output Response of the NWCT-100-420

4.4 Zero and Span Factory Calibration / Range

As an example, the NWCT-100-420 is shipped with the zero and span pots calibrated to yield the following input to output response:

Current Input (Amps AC)	Output (NWCT-100-420)	Output (NWCT-100-010)	Output (NWCT-100-020)	Output (NWCT-100-210)
0	4mADC	0VDC	0mADC	2VDC
100	20mADC	10VDC	20mADC	10VDC

4.5 Power/Overload LED

The NWCT's power indicator will be on steady when the power is applied. If the current level should exceed the input range of the on board analog to digital converter, the power LED will flash.

5. Electrical Specifications

Output	4-20mA, 0-10V, 0-20mA, 2-10V
Response Time	250mS
Accuracy	+/-0.8% of FS
Ambient Temperature Range	0 to 50 °C
Power Supply	24VAC/DC +15/-15%, Power consumption < 2 Watts
Line Frequency Range	47-400 Hz

6. Mechanical Dimensions

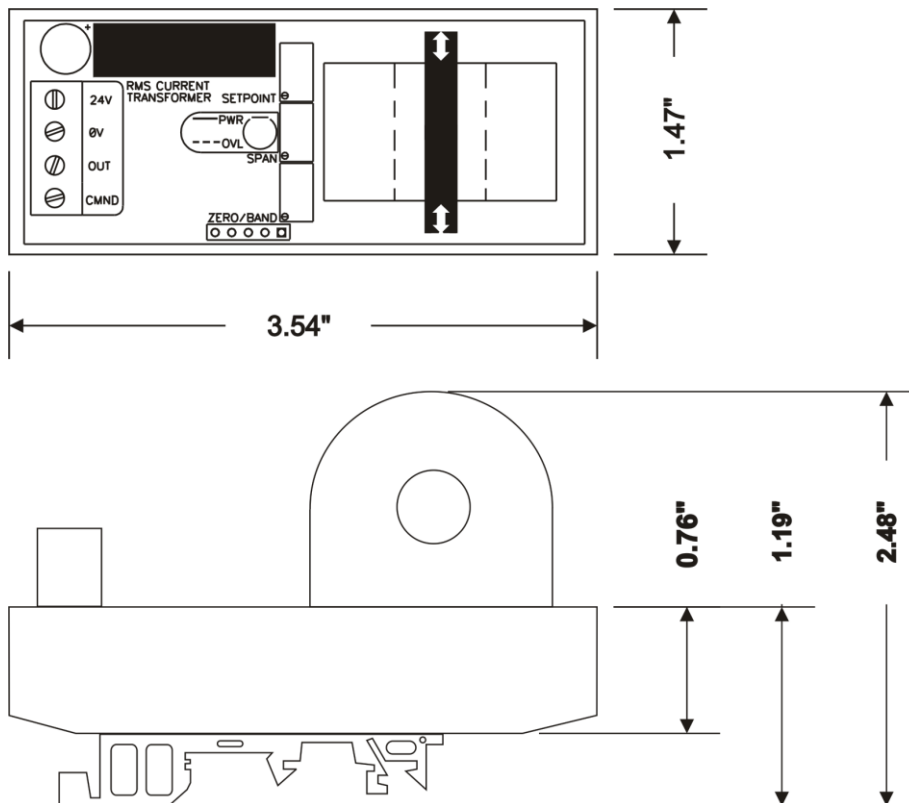

7. Contact Information

NuWave Technologies, Inc
866-379-3597
www.nuwaveproducts.com

8. WIRING DIAGRAM

