

## SSRMAN-1 SERIES USERS MANUAL

### SSR INTELLIGENT POWER CONTROL MODULE

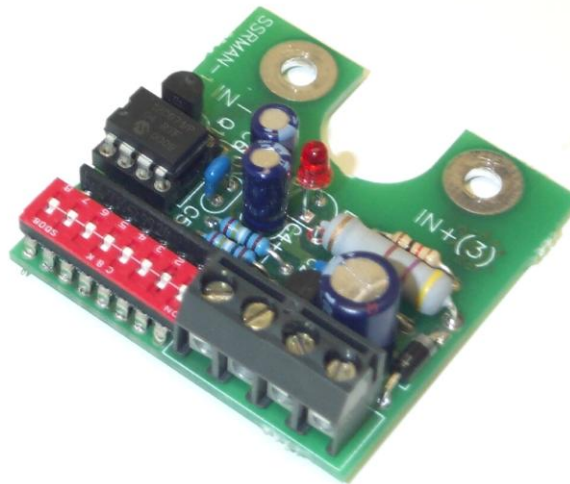

## TABLE OF CONTENTS

1. Ordering Code .....	2
2. Description.....	2
2.1 Features.....	2
3. Installation / Safety Information .....	2
3.1 Mounting Instructions.....	3
3.2 Electrical Connections .....	3
3.3 Limited Warranty.....	3
4. Operation.....	3
4.1 Power.....	3
4.2 24V Power Fusing.....	4
4.3 Command Input .....	4
4.3.1 Input Fail-safe Protection .....	4
4.4 Cycle Times .....	4
4.5 Configuration Dipswitch .....	4
4.6 Control Output.....	5
4.7 Output LED .....	6
4.8 Three Phase Operation.....	6
4.8.1 Three Phase Operation – Cycle Times .....	6
4.9 Wiring Multiple Units .....	6
4.9.1 Connecting Power & Commands In Parallel .....	6
4.10 Electrical Specifications .....	6
5. Mechanical Dimensions.....	8
6. Contact Information .....	8
7. General Connection Diagram .....	8
8. WIRING DIAGRAM (4-20mA, 0-5V, 0-10V Inputs) .....	9
9. WIRING DIAGRAM (Potentiometer Input) .....	9
10. WIRING DIAGRAM (0-135 Ohm Input) .....	10
11. WIRING DIAGRAM Three Phase Delta.....	11
12. WIRING DIAGRAM Three Phase Wye.....	11

## 1. Ordering Code

Part#	Description	Inputs
<b>SSRMAN-1</b>	SSR Mount Power Control Module, Time proportioning output, Volts, mA, Pot, Thermostat Input	0-10V, 0-5V, 2-10V, 1-5V, 4-20mA, 0-20mA, Potentiometer, 0-135Ω

## 2. Description

The SSRMAN-1 is a power control module designed for use with standard footprint zero cross or random fire SSRs (Solid State Relays). The module mounts directly on the SSR's input screws. The module operates by varying duty cycle of SSR's control input. The power delivered to the load is proportional to the command input signal.

### 2.1 Features

- Command input accepts 4-20mA, 0-10V, 0-5V, 0-135 Ω, Potentiometer
- Configurable for 4 different cycle times
- Drives multiple solid state relays (SSRs)
- Installs in seconds – mounts on SSR input screws
- Fits under finger-safe covers
- LED output indicator
- Limited 2 Year Warranty

## 3. Installation / Safety Information

Responsibility for determining suitability for use in any application / equipment lies solely on the purchaser, OEM and end user. Suitability for use in your application is determined by applicable standards such as UL, cUL and CE and the completed system involving this component should be tested to those standards.



**WARNING: FIRE HAZARD!!** Even quality electronic components **CAN FAIL KEEPING FULL POWER ON!** Provide a **SEPARATE (redundant) OVER TEMPERATURE SHUTDOWN DEVICE** to switch the power off if safe temperatures are exceeded.

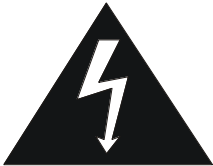

**WARNING: HIGH VOLTAGE!!** This control is installed on a Solid State Relay with high voltage on it. This control must be installed in a **GROUND**ED enclosure by a qualified electrician in accordance with applicable local and national codes including NEC and other applicable codes. Provide a safety interlock on the door to remove power before gaining access to the device.

### 3.1 Mounting Instructions

The SSRMAN-1 mounts directly to the control input terminals of an SSR. Some relays have short input screws and longer screws will required to reach through the contacts on the SSRMAN. Be sure to observe the correct polarity when mounting the module.

### 3.2 Electrical Connections

See the **WIRING DIAGRAMS** at the end of this document.

Before wiring the module, all Dip Switch settings for the command input and cycle time should be setup per the Configuration Dipswitch section.

### 3.3 Limited Warranty

NuWave Technologies, Inc. warrant this product to be free from defect in workmanship and materials for a period of two (2) years from the date of purchase.

1. Should unit malfunction, return it to the factory. If defective it will be repaired or replaced at no charge.
2. There are no user serviceable parts on this unit. This warranty is void if the unit shows evidence of being tampered with or subjected to excessive heat, moisture, corrosion or other misuse / misapplication.
3. Components which wear or damage with misuse are excluded, e.g. relays.
4. NuWave Technologies, Inc. shall not be responsible for any damage or losses however caused, which may be experienced as a result of the installation or use of this product. NuWave Technologies, Inc. liability for any breach of this agreement shall not exceed the purchase price paid E. & O.E.

## 4. Operation

### 4.1 Power

The SSRMAN-1 power requirement is 24VAC +/-10% or 24VDC +30%/-5%.

## 4.2 24V Power Fusing

Fusing may be accomplished by fusing each module separately or fusing groups of modules with either primary or secondary fusing. The current draw of each SSRMAN-1 is 65mA max.

## 4.3 Command Input

The SSRMAN-1 can accept 4-20mA, 0-10V, 0-5V, Potentiometer and 0-135  $\Omega$  inputs. All command inputs are not isolated from the 24V power Input. If more than one SSRMAN-1 is to be used from the same drive signal, separate power transformers are required. The type of command input can be configured via the dipswitch. The default setting is 0-5V/potentiometer. All command inputs are direct acting, meaning that as the input value increases, the control output increases in direct proportion.

Any leg of the command input can tolerate shorts to the ground input. Connecting the 24V power to the command input will cause damage to the unit.

### 4.3.1 Input Fail-safe Protection

If the signal sent to the SSRMAN-1's command input should become electrically open the control output will be forced to an off state when the 0-10V or 4-20mA inputs are selected. If the 135  $\Omega$  input becomes open the output will be full on. If the 0-5V/1-5V input becomes open the output state is typically off, but if fail safe protection is required when using the 0-5V/1-5V input, a 10K $\Omega$  resistor should be installed across the command input terminals and this will force the output state to off if the input signal becomes open.

## 4.4 Cycle Times

The SSRMAN-1 has 4 available cycle times of 200mS, 1S, 10S, and 100S.

Generally the cycle time should be chosen based on the mass of the load to be controlled; the larger the load mass, the longer the cycle time can be. Generally the its best to choose the longest cycle time that can be used without causing process ripple.

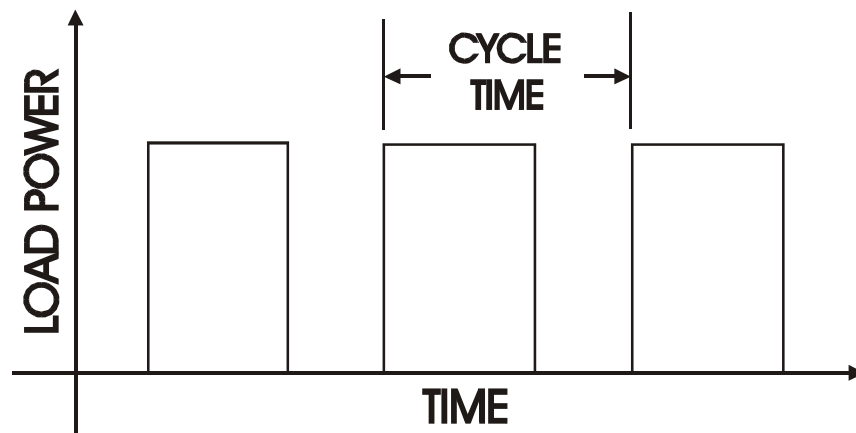

Cycle Time Plot

## 4.5 Configuration Dipswitch

The configuration dipswitch for the command input and cycle time setup is located on the top side of the SSRMAN-1 Module. Using a pen point gently push the switch to the right for ON according to the setup outlined in the table below. Power must be reset for changes in the dipswitch settings to take effect.

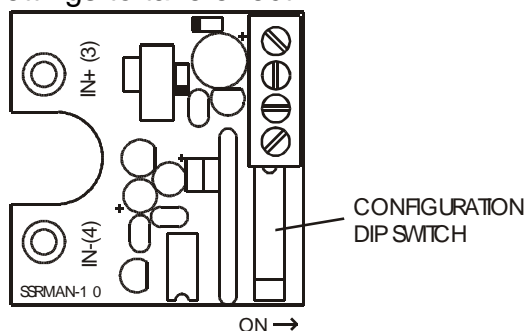

Command Input	1	2	3	6	7
0-135Ω	ON	OFF	OFF	ON	OFF
4-20mA	OFF	ON	OFF	OFF	ON
0-10V	OFF	OFF	ON	OFF	OFF
0-5V (Default)	OFF	OFF	OFF	OFF	OFF
Potentiometer	OFF	OFF	OFF	OFF	OFF
1-5V	OFF	OFF	OFF	OFF	ON
2-10V	OFF	OFF	ON	OFF	ON
0-20mA	OFF	ON	OFF	OFF	OFF

Cycle Time	4	5
200mS	OFF	OFF
1S	ON	OFF
10S	OFF	ON
100S	ON	ON

## 4.6 Control Output

The SSRMAN-1's SSR output drive is a DC pulsed current limited 8V@8mA (nominal) drive signal. This is more than enough current for driving most 3-32V standard SSRs, however it is still important to review the data sheet for the SSR you would like to use for compatibility with the SSRMAN-1's output drive. The table below shows the control output ratings for different power inputs, command inputs and control output voltages:

SSR Drive Output Rating Table for 0-5V, 0-10V, 4-20mA, Potentiometer Command Input Selection

Power Supply	SSR Drive Current (3V input to SSR)	SSR Drive Current (8V input to SSR)
24VAC +/-10%	20mA	8mA
24VDC +30%/-5%	20mA	8mA

SSR Drive Output Rating Table for 0-135Ω Command Input Selection

Power Supply	SSR Drive Current (3V input to SSR)	SSR Drive Current (8V input to SSR)
24VAC +/-10%	15mA	8mA
24VDC +30%/-5%	8.6mA	5mA

The control output can tolerate a direct short.

## 4.7 Output LED

The SSRMAN-1's RED output LED will turn on when the output is on. The output LED is wired in series with the SSR's input. If there is a poor connection on the SSR input terminals or a problem with the SSR's Input, the output LED will not become energized.

## 4.8 Three Phase Operation

One SSRMAN-1 can be used to control two poles of a three phase load using two SSRs with their control inputs wired in parallel. The Module should be wired as shown in the three phase wiring diagrams sections. The Control Output section should be reviewed to make sure that the total input current requirements of the two SSRs can be achieved with the SSRMAN-1.

### 4.8.1 Three Phase Operation – Cycle Times

When using the SSRMAN-1 to control three phase loads, the cycle time should be set for at least one second and preferably 10 or 100 seconds. This will maximize the control resolution and minimize any load imbalances.

## 4.9 Wiring Multiple Units

If more than one SSRMAN-1 is to be used from a non-isolated or common command signals:

1. A common power transformer can be shared. If the input selected is 0-10V or 0-5V, the inputs should be wired in parallel.
2. If multiple units must be powered from one power transformer and 4-20mA input is selected, one module should be set for 4-20mA and the remaining modules should be set for 1-5V.
3. If the command is 4-20mA, and the command inputs are to be wired in series, a separate power transformer for each module is required to isolate the inputs.

### 4.9.1 Connecting Power & Commands In Parallel

When multiple SSRMAN-1 power inputs and commands are wired in parallel, all of the GND terminals must be connected together follows:

Power:	Command:
GND---GND---GND----->	GND---GND---GND----->
24V-----24V-----24V----->	IN+-----IN+-----IN+----->

No crossing of the power input feed or command signal is permitted. If for some reason the power should become crossed, it will cause a direct short in the system. If properly fused, the fuse will blow and the SSRMAN-1 will not be damaged. If the command inputs are wired improperly, damage to SSRMAN-1 can result.

We do not guarantee operation of the SSRMAN-1 with any other manufacturer's SSR control module. Using them in the same circuit may cause either module to be damaged.

## 4.10 Electrical Specifications

Command Inputs	4-20mA, 0-10V, 0-5V, 0-135 $\Omega$ , Pot, 0-135 $\Omega$
Input Impedance	10K $\Omega$ (0-10V), 250 $\Omega$ (4-20mA), 100K $\Omega$ (0-5V)

0-135 $\Omega$ Excitation Current	20mA max
Control Output	SSR Drive, DC pulse, nominally 8V@8mA, 5V@5mA with 0-135 $\Omega$ input (see section 4.4)
Response Time	200mS
Output Resolution	0.5% for 4-20mA, 0-5V, pot and 0-10V. 1% for 0-135 $\Omega$
Output Linearity	1.5% for 4-20mA, 0-5V, pot and 0-10V. 5% for 0-135 $\Omega$
External Potentiometer Res.	10K $\Omega$ -25K $\Omega$
Ambient Temperature Range	0 to 70 $^{\circ}$ C
Power Supply	24VAC +15/-10%, 24VDC +30%/-5%
	Power consumption less than 2 Watts

## 5. Mechanical Dimensions

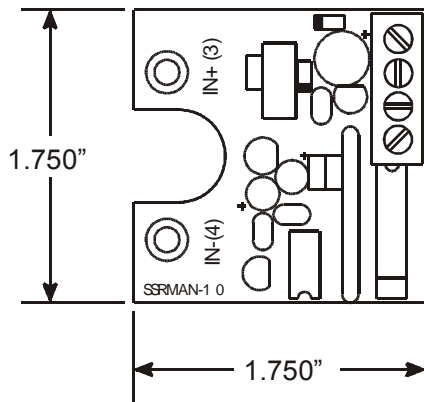

Max Height is 0.6"

## 6. Contact Information

NuWave Technologies, Inc  
 866-379-3597  
[www.nuwaveproducts.com](http://www.nuwaveproducts.com)

## 7. General Connection Diagram

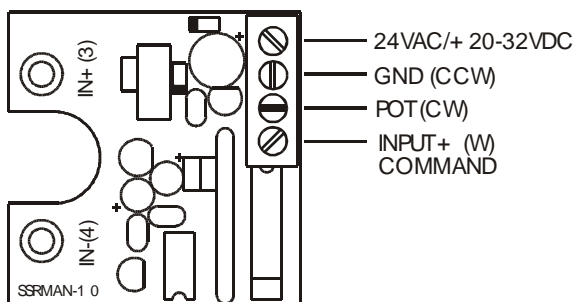

### 8. WIRING DIAGRAM (4-20mA, 0-5V, 0-10V Inputs)

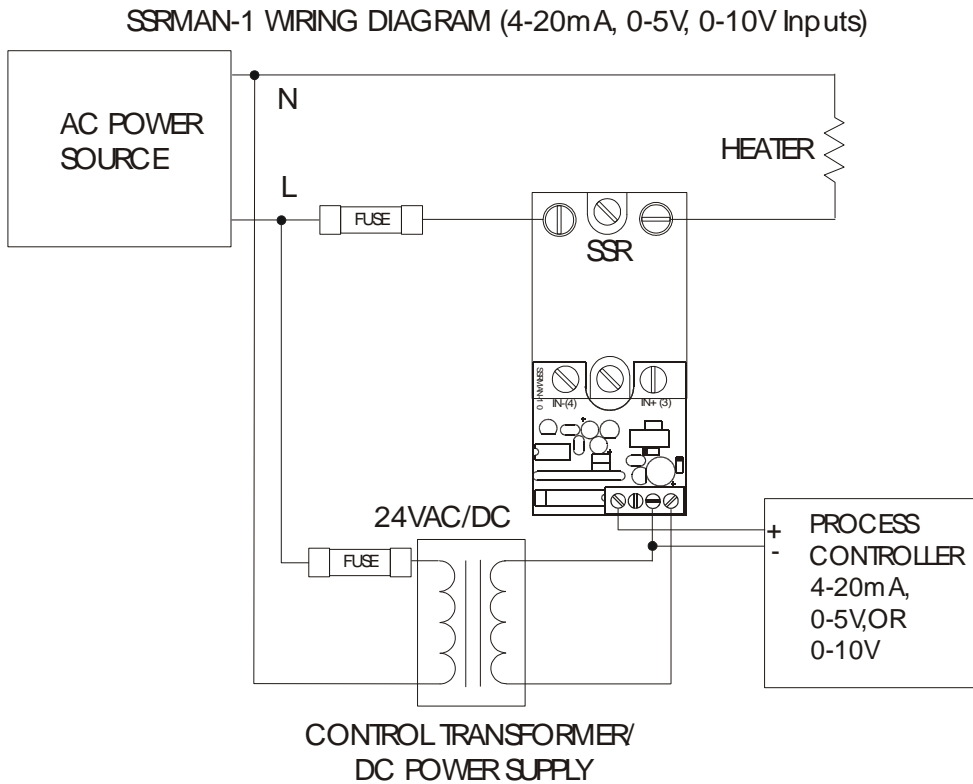

### 9. WIRING DIAGRAM (Potentiometer Input)

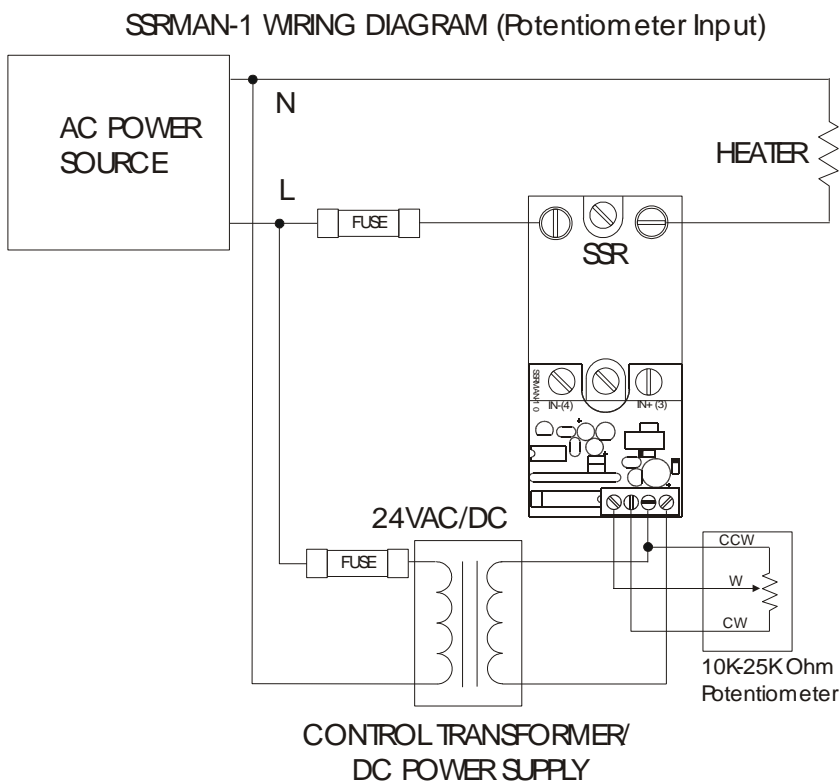

## 10. WIRING DIAGRAM (0-135 Ohm Input)

SSRMAN-1 WIRING DIAGRAM (0-135 Ohm Input)

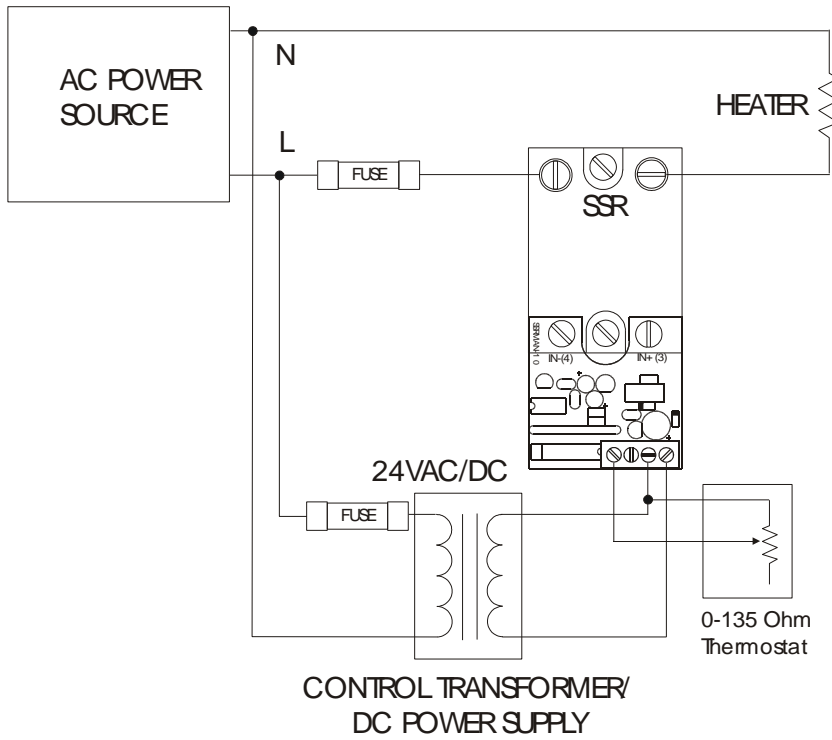

**11. WIRING DIAGRAM Three Phase Delta**  
**3 PHASE DELTA CONNECTION**  
**SSRMAN-1 LOAD WIRING DIAGRAM**

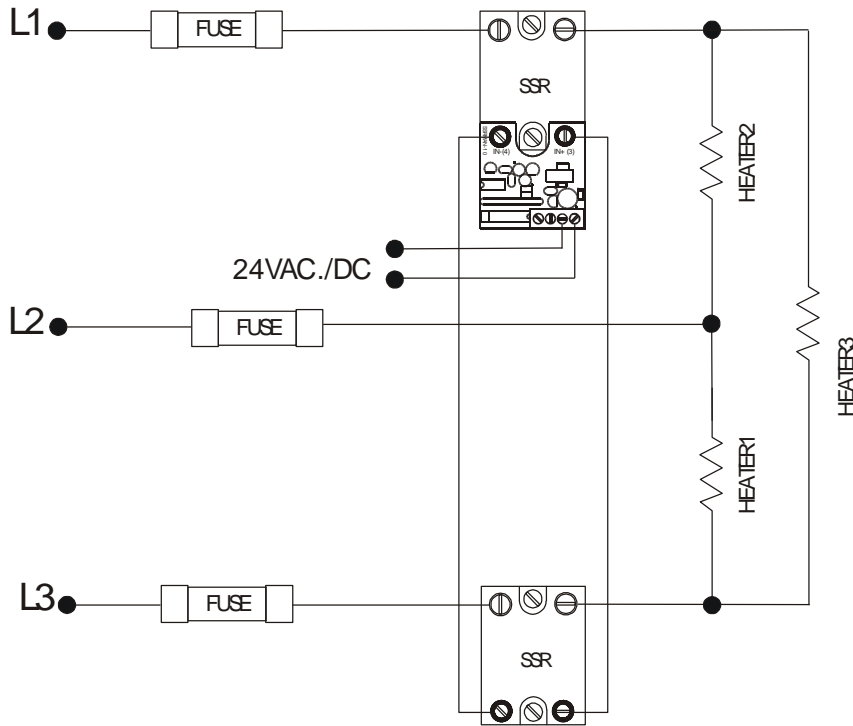

**12. WIRING DIAGRAM Three Phase Wye**  
**3 PHASE WYE CONNECTION**  
**SSRMAN-1 LOAD WIRING DIAGRAM**

